

IMPORTANT INSTRUCTIONS

Foredom® Handpieces H.50 and H.50C

Please read these safety instructions thoroughly before operating this tool. They are for your protection and should always be followed to reduce the risk of personal injury or damage to the handpiece.

Never run Handpiece in Reverse direction.

See your Power Tool Owner's Manual for complete instructions on use, care and maintenance.

For More Information

For more information on Foredom machines, handpieces, or accessories, contact your local dealer. When no local dealer is available, write The Foredom Electric Company, 16 Stony Hill Road, Bethel, CT 06801, call (203) 792-8622, or visit our website at www.foredom.com.

Always wear proper eye protection while using this handpiece.

Never use a damaged, bent, vibrating, or out of balance chisel, cutter, gouge, or other tool bit.

Form 1214 n 12/07

Printed in U.S.A.

Cutting Tips

Practice a little on some scrap wood to become familiar with the feel and characteristics of the H.50 Handpiece and cutters.

For the best results the angle of the handpiece to the work should be about 45° when using a V type cutter. Carve at a 30° angle when using round edged cutters and gouges.

Press the cutting tip into the wood gently and increase the flexible shaft speed slowly to make fine shallow cuts.

To make deeper cuts add a little more pressure.

Always cut away from your other hand or body.

Optimum Cutting Speed is 3,000—10,000 RPM.

To operate within this range, we recommend the use of a bench top dial control (EM or EMX) in place of the more common foot pedal. Running at higher speeds will lead to heat, vibration, and excess cam wear.



LIMITED WARRANTY

Foredom® warrants its product to be free of defects in material or workmanship for a period of 90 days after purchase. During the warranty period, the defective product will be repaired or replaced without charge or, at our option, the purchase price will be refunded. This warranty does not cover damage caused in transit or by accident, misuse, or ordinary wear.

ALL IMPLIED WARRANTIES, INCLUDING BUT NOT LIMITED TO WARRANTIES OF FITNESS AND MERCHANTABILITY, ARE HEREBY LIMITED IN DURATION TO A PERIOD ENDING 90 DAYS FROM DATE OF PURCHASE, AND WE WILL NOT BE LIABLE OR RESPONSIBLE FOR ANY SPECIAL OR CONSEQUENTIAL DAMAGES. Repair or replacement will be made at our option if the product is returned post-paid to:

The Foredom Electric Company
16 Stony Hill Road, Bethel CT 06801

All warranty repairs must be done at the factory at the address above. We will not pay any shipping or transportation charges. This warranty covers the original purchaser of the product only. Some states do not allow limitations on how long an implied warranty lasts, so the above limitation may not apply to you. This warranty gives you specific legal rights, and you may also have other rights which vary from state to state.

Safety Instructions

The H.50 Chisel Handpiece can only be used in the forward motor rotation direction. Using the H.50 Handpiece in reverse will cause severe damage to the handpiece and flexible shaft.

Always wear proper eye and face protection. Wear safety glasses or a face shield whenever you operate a Foredom Flexible Shaft machine or any power tool to prevent serious eye injury.

The H.50 Handpiece should only be used with Foredom Cutters. Never use other chisels and gouges in this handpiece as they may not fit properly or be too large for safe use.

Do not run or use the handpiece while the locking nut is loose. Cutters, chisels and gouges should be kept sharp. Dull or blunt tools require more effort while sharp tools cut easily and with more control.

Never change cutters, chisels, gouges, or tool bits while motor switch is in the **ON** or **FOR** (forward) or **REV** (reverse) position.

Never sharpen cutter, chisel or gouge when it is mounted in the No. H.50 Handpiece. Always remove chisel or tool bit for sharpening.

Never use or continue to use any chisel, cutter, gouge or other tool bit that is damaged, bent, loose, vibrating or out of balance. Inspect each accessory for cracks or flaws before using it.

Avoid knots, imperfections in the wood or metal objects like nails, which could catch or damage the tool bit. Let the speed of the tool do the work. **Do not apply heavy pressure to the tool bit.**

Always insert the cutter, chisel or gouge fully into the plunger shaft slot. Never use an adapter, extension or other device to mount other chisels, cutters or gouges.

Secure the work piece that you are carving in a vise or other work holding device. Holding it with your hand is dangerous and can result in serious hand injury.

Never wear open shoes or sandals. Use footwear that is tough enough to protect your feet from falling tools.

Keep both hands and fingers away from the cutting edge at all times.

Never cut or exert pressure, toward your hand or any other part of your body.

Do not wear loose fitting clothing or jewelry. Loose clothing or jewelry can be come entangled in the tool. Do not wear items such as neckties, necklaces, or bracelets when operating power tools. Secure or tie back long hair.

Use both hands whenever possible to hold and guide the carving tool.

Always use a proper dust collection system or wear a respirator to prevent the inhalation of dust particles, or other debris into the lungs.

Assembly Instructions

Attaching the Handpiece

To attach the handpiece, be



sure that the keyed tip of the flexible shaft is properly lined up with the slot in the back end of the handpiece by looking into the rear of the handpiece before pushing it on. If it is not in line, turn the shaft tip or the handpiece to the correct position (see illustration). To remove the handpiece, simply pull the handpiece off the shaft and sheath with a firm grip while the motor is not running.

Maintenance and Lubrication

The H.50 Handpiece requires little maintenance to keep it running at peak performance. Keep it dry, free of debris and lubricated for a long trouble free life.

After every 200 hours of use you should clean and lubricate the H.50 Handpiece. The old grease must be cleaned off of the interior cam chamber and replaced with new lubricant.

1. First remove the chisel, gouge or cutter tip from the handpiece.
2. Next remove the handpiece from the flexible shaft. Follow "Attaching Handpiece Instructions" on opposite side of this page.

3. Unscrew (counter clockwise) the aluminum housing ring (#15) and Q.D. connector (#12). To prevent the pliers from marring the aluminum, wrap it in a rag or piece of leather.

4. Now you can carefully separate the halves of the black plastic top housing (#6) and bottom housing (#14). Keep the spindle/plunger assembly in one half of the black plastic housing. Be careful not to lose or displace the small pin guide inserts (#5).

5. Gently wipe out the grease from the empty half of the housing with a small clean rag or Q-tip.

6. Carefully remove the spindle/plunger assemblies making sure not to disassemble either and gently wipe off the old grease with a soft clean rag.

7. Clean the other half of the housing with a small clean rag or Q-tip and replace the cleaned spindle/plunger assemblies in one half of the housing.

8. Squeeze a thin line (1/8" thick, no more!) of Foredom® Chisel Handpiece Grease (p/n MS10008) from the plunger pin (#3) to the furthest of the two actuating cam gears (#13). **Do Not** put grease beyond this cam as the ball bearings do not require grease.

9. Replace the remaining half of the housing taking care that the plunger pin is inserted in the pin guide insert (#5) and that the sleeve bearings and ball bearing fit into their respective slots.

10. Carefully screw the metal Q.D. connector and metal housing ring onto the softer plastic top and bottom housing, making sure that you do not cross-thread them. Attach the handpiece to the flexible shaft and run slowly for 5 minutes to redistribute the grease before resuming carving.

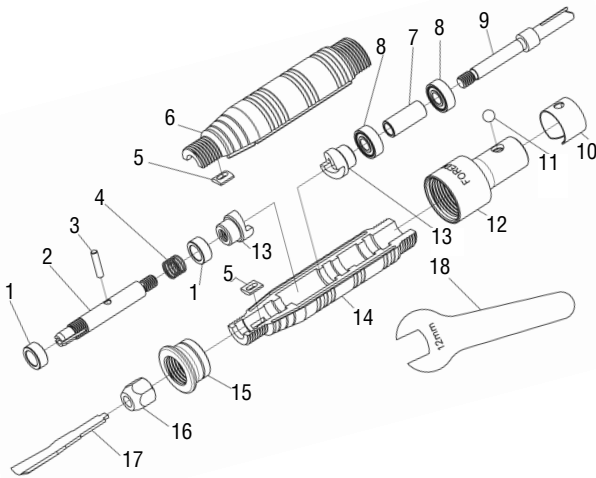

- | | |
|--------------------------|-----------------------------|
| 1- Sleeve Bearing | 20- Catch Spring |
| 2- Plunger Shaft | 21- Catch Ball |
| 3- Plunger Pin | 22- Q.D. Connector |
| 4- Plunger Spring | 23- Actuating Cam (2) |
| 5- Pin Guide Insert (2) | 24- Bottom Housing (female) |
| 6- Top Housing (male) | 25- Housing Ring |
| 7- Spacer | 26- Locking Nut |
| 8- Ball Bearing | 27- Power Carving Gouge |
| 9- Slotted Drive Spindle | 28- Wrench, 12mm |

Attaching and Mounting Cutters, Chisels, or Gouges

1. Remove the H.50 Handpiece from the flexible shaft or make sure that the flexible shaft motor switch is in the OFF position.

2. Loosen the locking nut with the 12mm spanner wrench (provided) by unscrewing it counter clockwise.

3. Choose a chisel, gouge, or cutter and with the protective cap still in place insert the tang fully into the plunger shaft. Tighten the locking nut clockwise until chisel or tool bit is held securely. **Do not over tighten.** Once the accessory tip is mounted and the protective cap is removed, you can reattach the handpiece, turn on the flexible shaft machine and begin to carve.

